



**AIR OPERATED
DOUBLE
DIAPHRAGM
PUMPS**



ISO 9001: 2008
ISO 14001: 2004

pricepumps.co.in

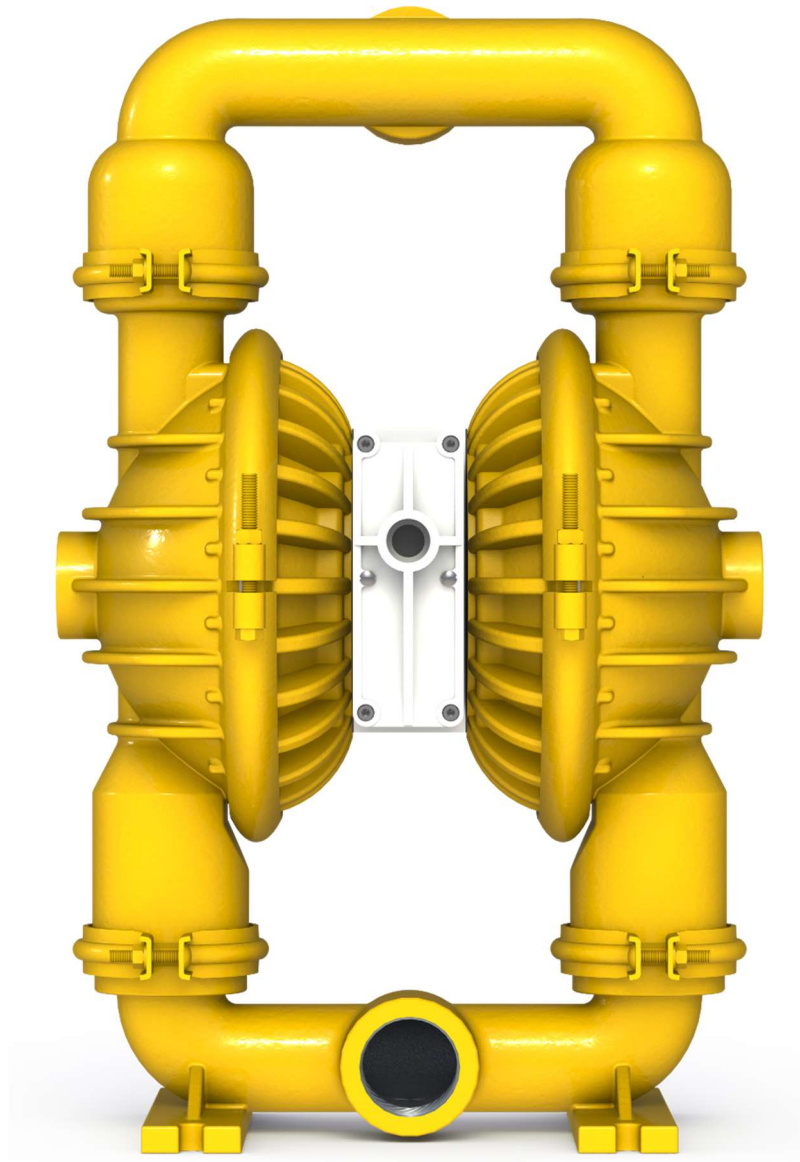

**2" ALUMINIUM PUMP
AOD 50 PFF AAGP/HYT/TF/A**

pricepumps.co.in



AIR OPERATED DOUBLE DIAPHRAGM PUMPS



ISO 9001: 2008
ISO 14001: 2004

pricepumps.co.in

SECTION 1- LEGEND

2" ALUMINIUM PUMP

AOD 50/AAGP/HYT/TF/A

MODEL: AOD 50 PFF ALUMINIUM

51mm (2") Pump

Maximum Flow Rate: 681 Lpm (180 gpm)

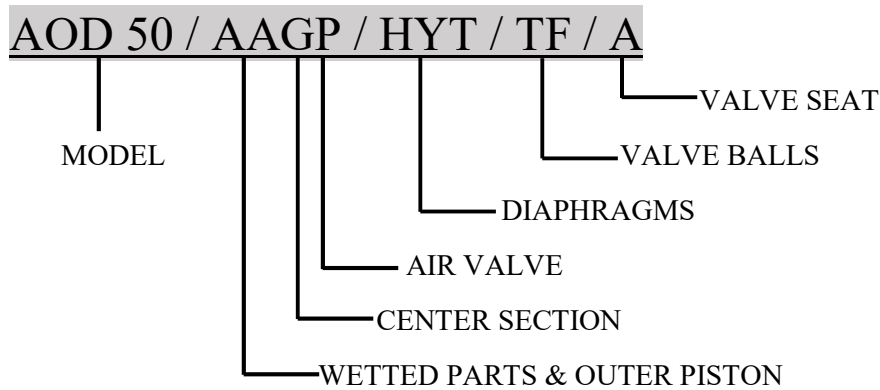

MATERIAL CODES

MODEL
AOD 50 = 2" PUMP

AIR VALVE
P = POLYPROPYLENE

VALVE BALL
TF = TEFLON

WETTED PARTS & OUTER PISTON
AA = ALUMINIUM/
ALUMINIUM

DIAPHRAGMS
HYT = HYTREL

VALVE SEAT
A = ALUMINIUM

CENTER SECTION
G = GLASS FILLED
POLYPROPYLENE



AIR OPERATED DOUBLE DIAPHRAGM PUMPS



ISO 9001: 2008
ISO 14001: 2004

pricepumps.co.in

SECTION 2 – SPARE PART LIST

2” ALUMINIUM PUMP

AOD 50/AAGP/HYT/TF/A

SR No.	DISCRIPTION	PART No	QTY
1	LIQUID CHAMBER	50-1002-01	2
2	SUCTION MANIFOLD	50-1021-01	1
3	DISCHARGE MANIFOLD	50-1031-01	1
4	NRV BALL	50-1041-55	4
5	BALL SEAT	50-1071-01	4
6	SEAT ENVELOP GASKET	50-3302-55	4
7	HOLDING PLATE	50-1112-01	2
8	LOCK NUT	50-1132-01	2
9	DIAPHRAGM	50-2052-56	2
10	BACK UP DIAPHRAGM	N/A	-
11	SUCTION DISCHARGE CLAMP	50-1222-61	8
12	CHAMBER CLAMP	50-1232-61	4
13	CENTER BLOCK	40-1301-23	1
14	REDUCER	40-1376-21	1
15	CENTER BLOCK PATTI	40-1319-03	4
16	CENTER BLOCK PIPE	40-1318-03	4
17	CENTER BLOCK O RING	40-3155-56	4
18	MAIN SHAFT	50-1341-03	1
19	AIR COVER GASKET	40-3311-51	2
20	AIR COVER	50-1402-01	2
21	PILOT BUSH	40-1471-07	1
22	PILOT SHAFT	40-1451-03	1
23	PILOT BUSH O RING	40-3161-51	4
24	PILOT SHAFT O RING	15-3176-56	4
25	PILOT SHAFT LOCK O RING	40-3181-51	2



AIR OPERATED DOUBLE DIAPHRAGM PUMPS



ISO 9001: 2008
ISO 14001: 2004

pricepumps.co.in

SECTION 2 – SPARE PART LIST (CONTINUED...)

2" ALUMINIUM PUMP

AOD 50/AAGP/HYT/TF/A

SR NO.	DISCRIPTION	PART NO.	QTY
26	PISTON BLOCK	40-1501-20	1
27	PISTON	40-1521-69	1
28	PISTON/CAP O RING BIG	40-3201-51	2
29	PISTON O RING SMALL	40-3222-51	4
30	PISTON RING BIG	40-3241-68	1
31	PISTON RING SMALL	40-3246-68	4
32	PISTON BLOCK CAP	40-1571-20	1
33	PISTON BLOCK COVER	40-1561-20	1
34	PISTON BLOCK GASKET	40-3321-51	1
35	PISTON BLOCK COVER GASKET	40-3331-51	1
36	EXHAUST	40-1366-23	1
37	AIR NIPPLE	50-1371-07	1
38	3/8" X 90 MM HEX BOLTS SS (CHAMBER BOLTS)	04-6024-03	4
39	3/8 X 19 X 6 MM MS WASHER (CHAMBER)	04-6208-61	8
40	5/16" X 45 MM CARRIAGE BOLTS SS (SUC/DIS)	04-6035-03	8
41	3/8" X 1 1/4" HEX BOLTS SS (AIR COVER)	04-6016-03	8
42	3/8 X 20.7 X 1.5 MM SS WASHER (CHAMBER)	04-6210-03	4
43	3/8 MS HEX NUT	04-6304-61	8
44	1/4" X 4" ALLEN BOLTS MS (P B)	04-6005-61	4
45	P B SCREW MS	04-6321-61	2
46	5/8 X 35 X 3 MM MS WASHER (H P)	04-6217-61	2
47	3/8 X 3 MM SS WASHER (AIR COVER)	04-6206-03	8



AIR OPERATED DOUBLE DIAPHRAGM PUMPS



ISO 9001: 2008
ISO 14001: 2004

pricepumps.co.in

SECTION 3 – EXPLODED VIEW

2" ALUMINIUM PUMP

AOD 50/AAGP/HYT/TF/A

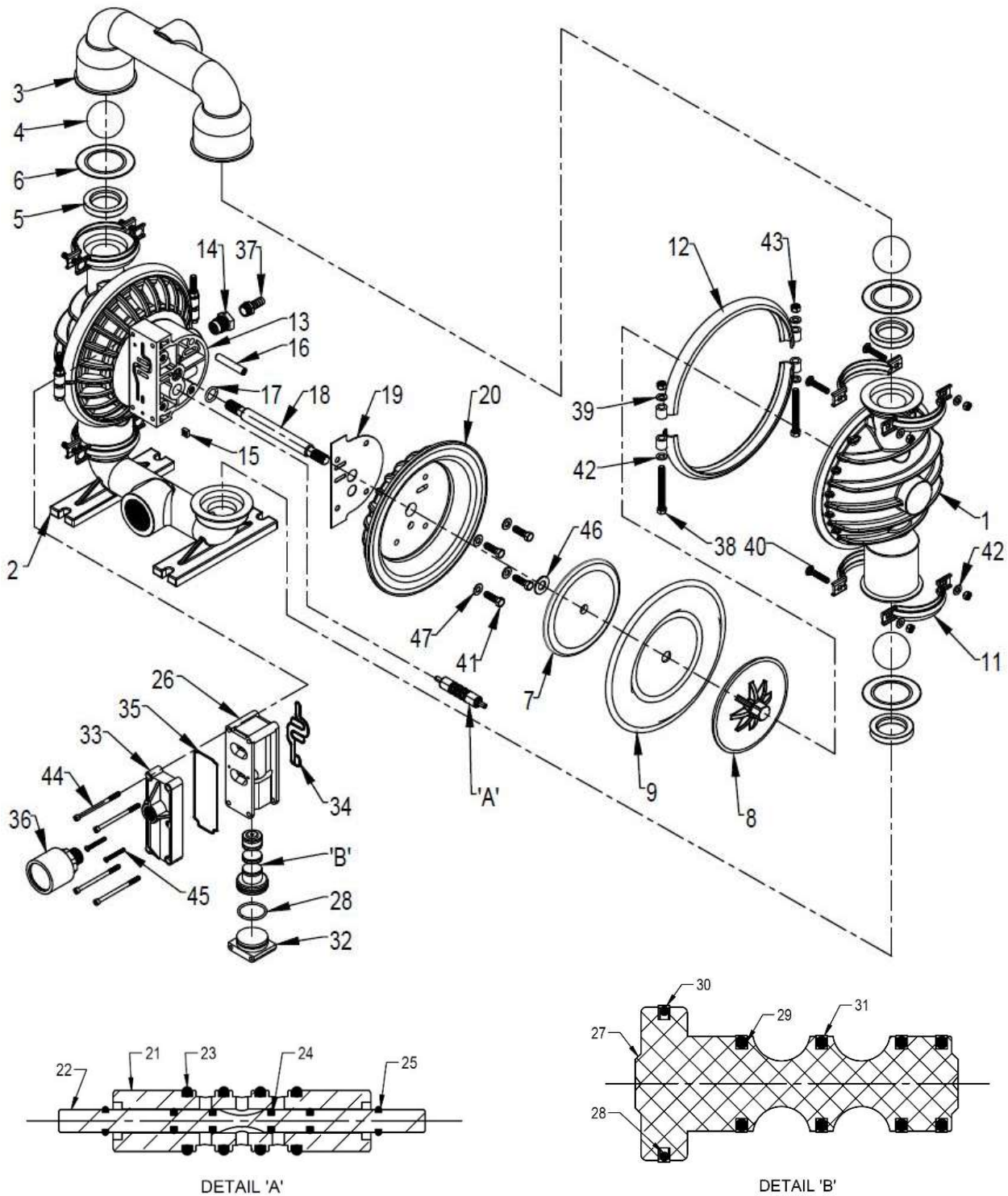



AIR OPERATED DOUBLE DIAPHRAGM PUMPS



ISO 9001: 2008
ISO 14001: 2004

pricepumps.co.in

SECTION 4 – DIMENSIONAL DRAWING

2" ALUMINIUM PUMP

AOD 50/AAGP/HYT/TF/A

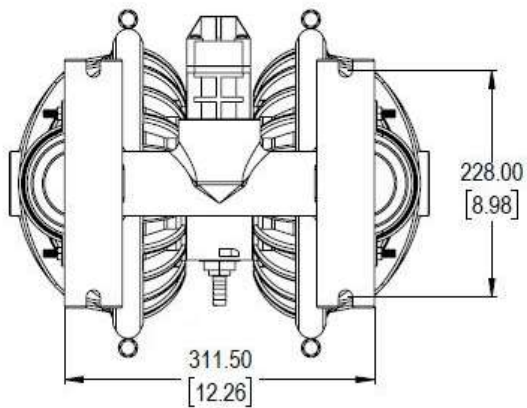
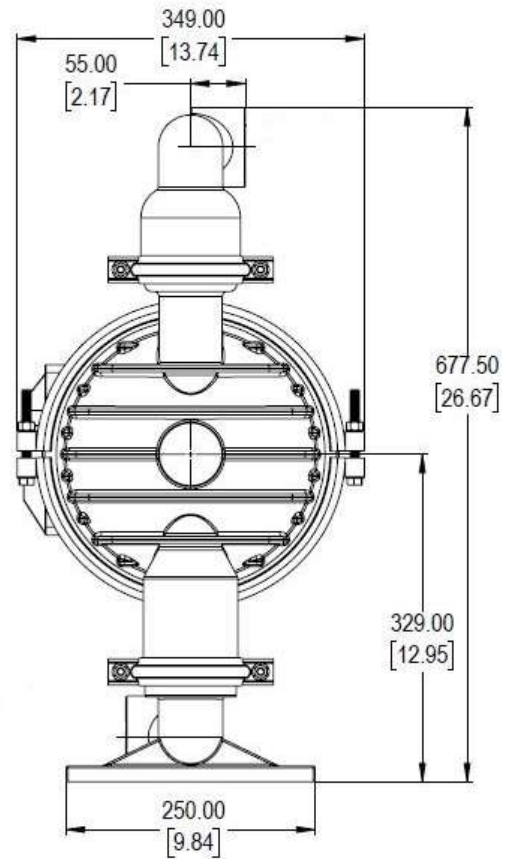
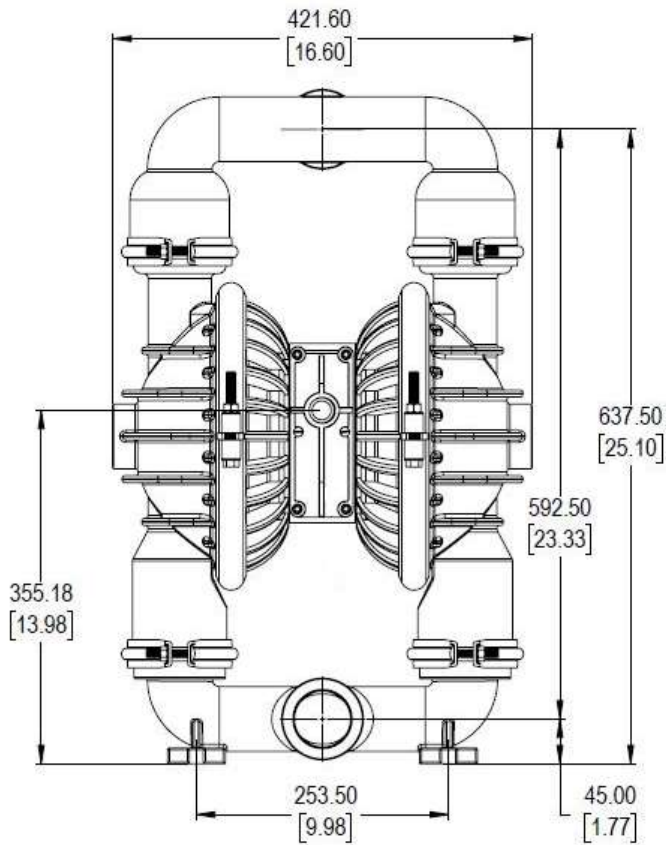



AIR OPERATED DOUBLE DIAPHRAGM PUMPS



ISO 9001: 2008
ISO 14001: 2004

pricepumps.co.in

SECTION 5 – SPECIFICATION & PERFORMANCE

2" ALUMINIUM PUMP

AOD 50/AAGP/HYT/TF/A

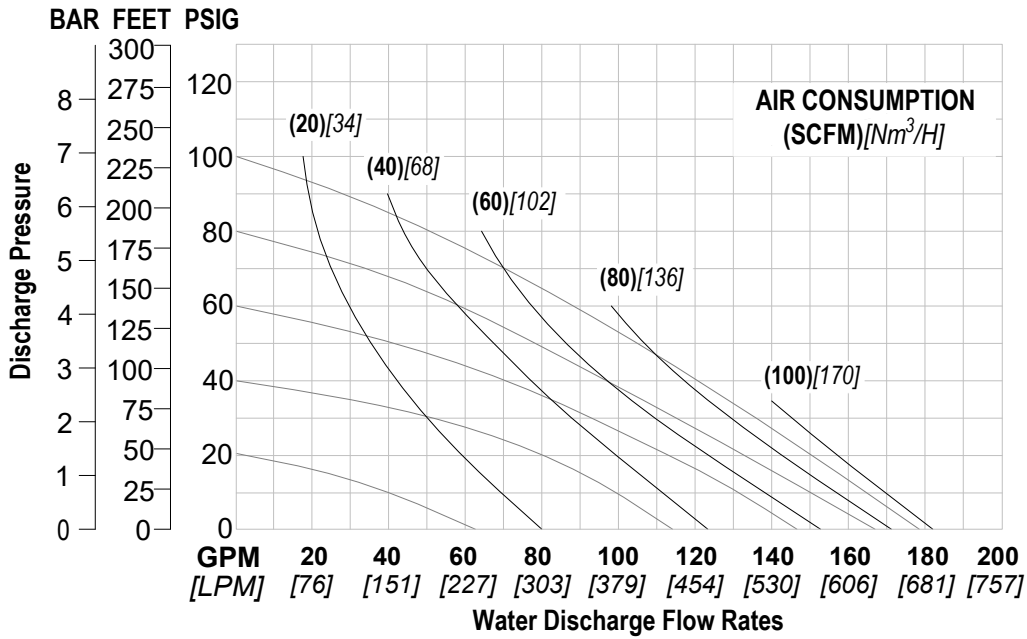

SPECIFICATIONS:

MAX FLOW RATE: 681 Lpm (180 gpm)
 MAX AIR PRESSURE: 105 PSI (7 Bar)
 AIR INLET: 13 mm (1/2" BSP)
 PORT INLET: 51 mm (2" BSP)
 DISCHARGE: 51 mm (2" BSP)
 SUCTION LIFT: DRY: 7.2 m (23.8')
 WET: 9.0 m (29.5')
 MAX PARTICLE SIZE: (Dia) 6.4 mm (1/4")
 AIR EXHAUST: (3/4" BSP)

SHIPPING DIMENSIONS:

HEIGHT: 740mm (29.13")
 WIDTH: 370mm (14.56")
 LENGTH: 440mm (17.32")
 WEIGHT: 32.5 Kgs

Price Pumps meet ISO 9001-2015, ISO 14001 & CE quality standards.



**AIR OPERATED
DOUBLE
DIAPHRAGM
PUMPS**



ISO 9001: 2008
ISO 14001: 2004

pricepumps.co.in

NOTES: